

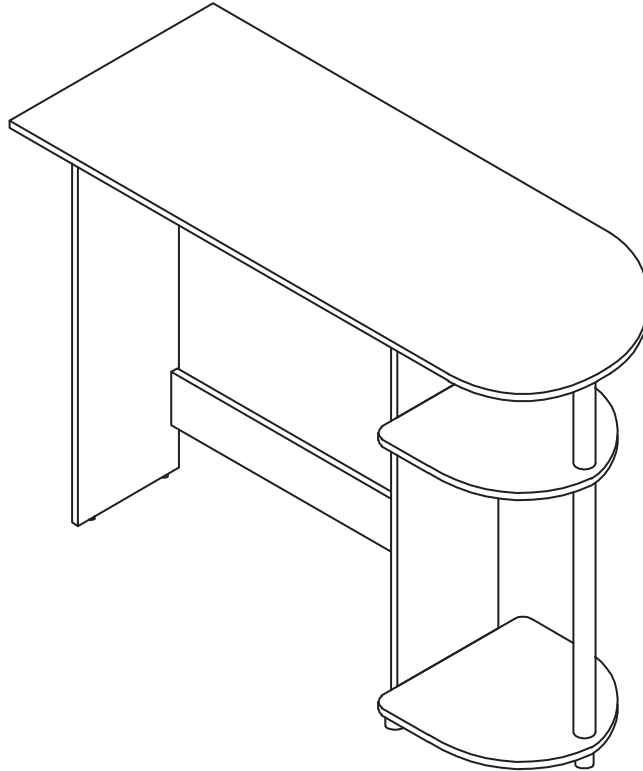

fourstargroup

ITEM: 11210850 DOT

THIS INSTRUCTION BOOKLET CONTAINS **IMPORTANT** SAFETY INFORMATION. PLEASE READ AND KEEP FOR FUTURE REFERENCE. THIS INSTRUCTION MANUAL IS PRINTED ON RECYCLED PAPER USING EARTH FRIENDLY SOY BASED INK.



UPC#4893948120444

COMPUTER DESK



Do not return to the store

Do you have any questions ? Missing small parts or hardware?
If you need assistance with the assembly of your **COMPUTER DESK** please contact our Customer Service Department by visiting www.fourstari.com or emailing us at support@fourstari.com or call us at 508-473-7688 or 800-639-3803.

Please provide the following information:

1. Name of the store purchased from.
 2. Date of purchase.
 3. Item, Model, Style or SKU number listed on the instructions or box.
 4. Description of the actual item in question.
 5. Part number, Description of the part and quantity needed.
 6. Copy of proof of purchase from an authorized retailer is required.
- This information will help us fulfill your request efficiently.

LOT#

DATE PURCHASED

____ / ____ / ____

BEFORE YOU BEGIN, PLEASE READ ASSEMBLY INSTRUCTIONS CAREFULLY. FOLLOW THEM STEP BY STEP.

CAUTION:

- 1. ADULT SUPERVISION IS REQUIRED DUE TO SMALL PARTS. CARE SHOULD BE TAKEN IN THE UNPACKING AND ASSEMBLY OF THE PRODUCT.**
- 2. ASSEMBLE ON SOFT SURFACES TO PREVENT DAMAGE TO THE PRODUCT FINISH.**
- 3. MAKE SURE ALL PARTS ARE INCLUDED BEFORE ASSEMBLY.**

ASSEMBLY TOOLS REQUIRED

RUBBER MALLET

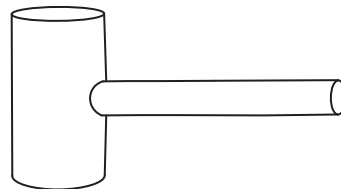

SCREWDRIVER

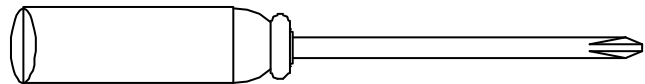

WARNING!!!



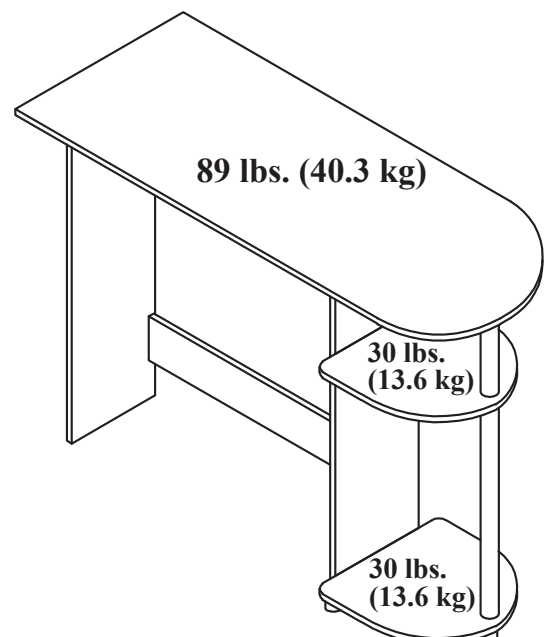

This unit is intended for use only with the products and maximum weights indicated. Use with other products or products heavier than the maximum weights indicated may result in instability causing possible injury. Furniture can tip over or break if improperly moved. Have a friend help to lift and carry the unit to its new location.





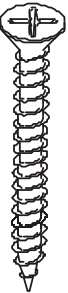

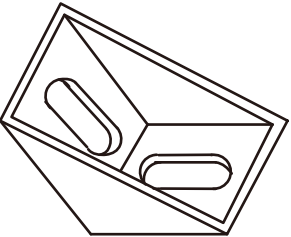
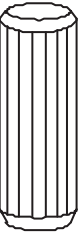

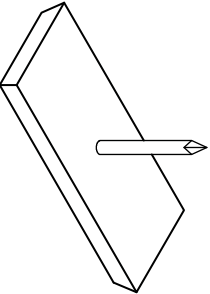



PARTS AND HARDWARE

BEFORE YOU BEGIN, PLEASE FOLLOW ASSEMBLY INSTRUCTIONS CAREFULLY. FOLLOW THEM STEP BY STEP.

HARDWARE LIST

PART NAME	LINE-ARTDRAWING	SIZE	QTY
5 38MM SCREW 1.49" SCREW		38mm Flat Head 1.49" Flat Head	12 PCS
6 12MM SCREW 0.47" SCREW		1.2cm Flat Head 0.47" Flat Head	4 PCS
7 L BRACKET 20MM L BRACKET 0.79"		2 x 2cm 0.79" x 0.79"	2 PCS
8 WOODEN DOWEL		0.6 x 3cm 0.23" x 1.18"	6 PCS
9 WHITE GLUE		N/A	1 PC
10 FOOT W/PIN		3cm x 1.3cm 1.18" x 0.51"	4 PCS

PARTS LIST

PART NAME	LINE-ARTDRAWING	SIZE	QTY
1 LONG TUBE		3.8 x 3.8 x 44cm 1.49" x 1.49" x 17.32"	1 PC
2 MEDIUM TUBE		3.4 x 3.4 x 21.4cm 1.34" x 1.34" x 8.42"	1 PC
3 FOOT		3.4 x 3.4 x 3.8cm 1.34" x 1.34" x 1.49"	1 PC
A TOP PANEL WITH THE CAP INSERTED		80 x 39.5 x 1.5cm 31.5" x 15.55" x 0.59"	1 PC
B LEFT SIDE PANEL		71.4 x 23 x 1.2cm 28.11" x 9.05" x 0.47"	1 PC
C RIGHT SIDE PANEL		71.4 x 23 x 1.2cm 28.11" x 9.05" x 0.47"	1 PC
D CROSSBAR		53.4 x 3.5 x 1.2cm 21.02" x 1.37" x 0.47"	2 PCS
E BOTTOMBACK PANEL		53.4 x 9 x 1.2cm 21.02" x 3.54" x 0.47"	1 PC
F SIDE CENTER SHELF		29.5 x 23 x 1.2cm 11.61" x 9.05" x 0.47"	1 PC
G SIDE BOTTOM SHELF		34 x 23 x 1.2cm 13.38" x 9.05" x 0.47"	1 PC

ASSEMBLY INSTRUCTIONS

STEP 1

ATTACH L-BRACKETS (7) TO BOTH CROSSBARS (D) USING SCREWS (6).

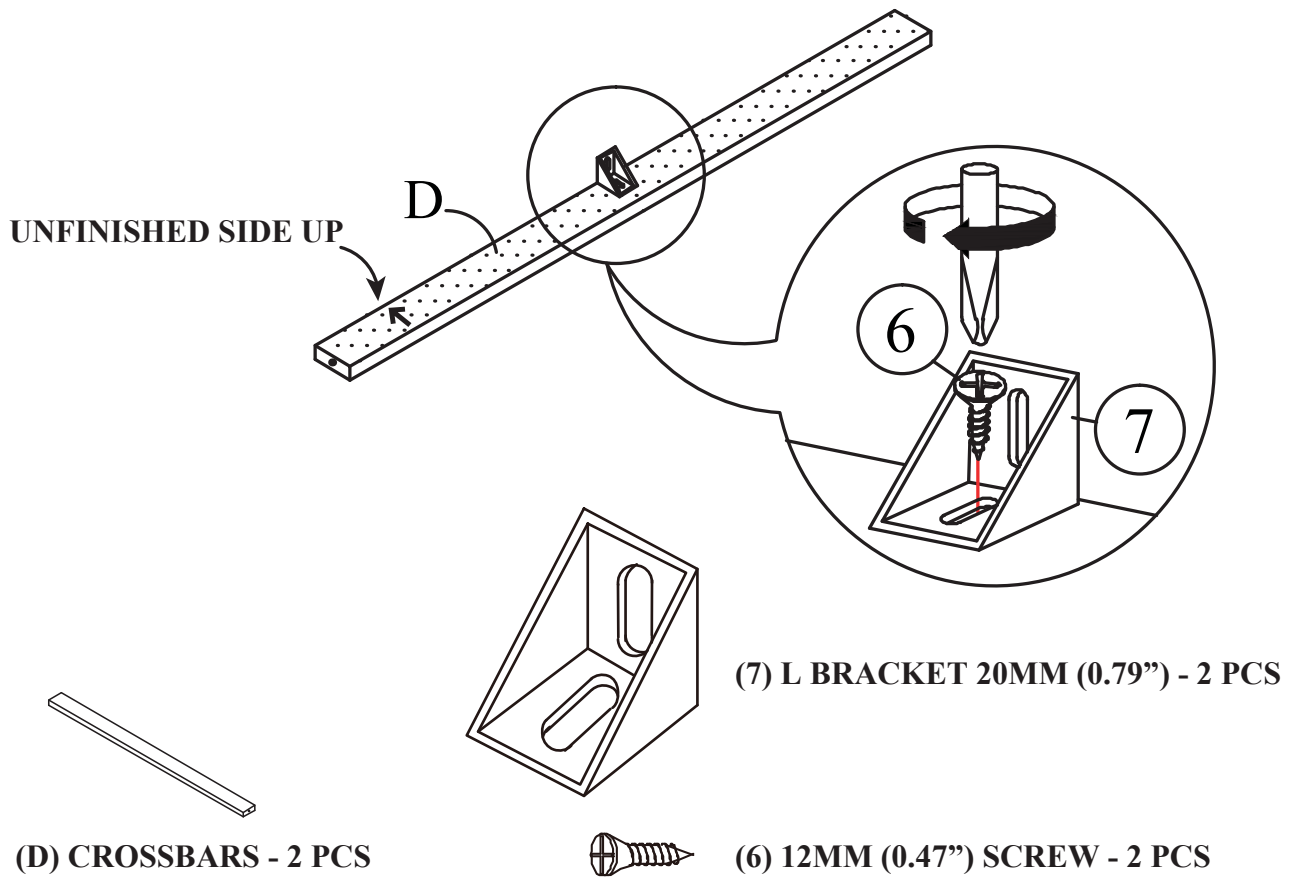

STEP 2

ATTACH MEDIUM TUBE (2) TO INSERT CAP. DO NOT OVER TIGHTEN TUBE.

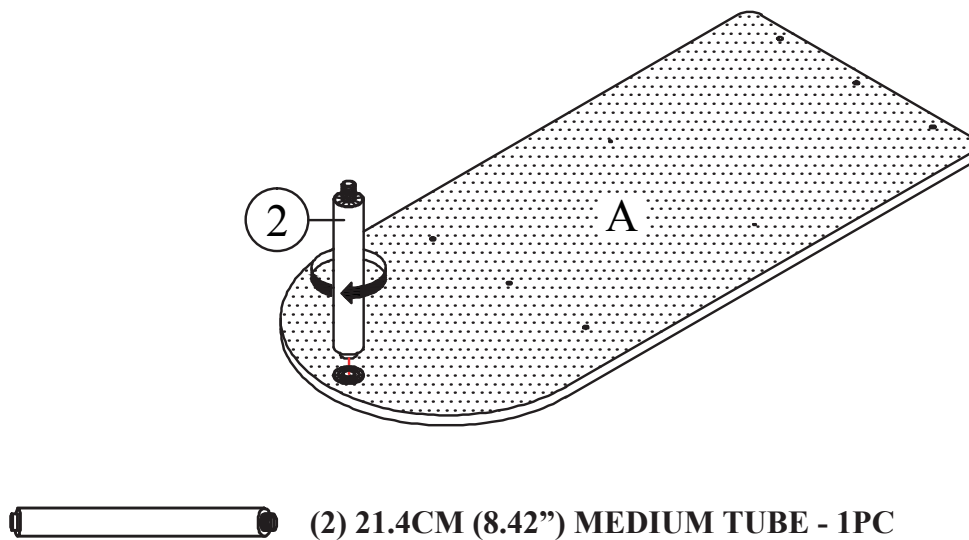

STEP 3

INSERT DOWELS (8) INTO ONLY HALF OF THE DOWEL HOLES INTO THE TOP OF SIDE PANELS (B) & (C) WITH GLUE (9).

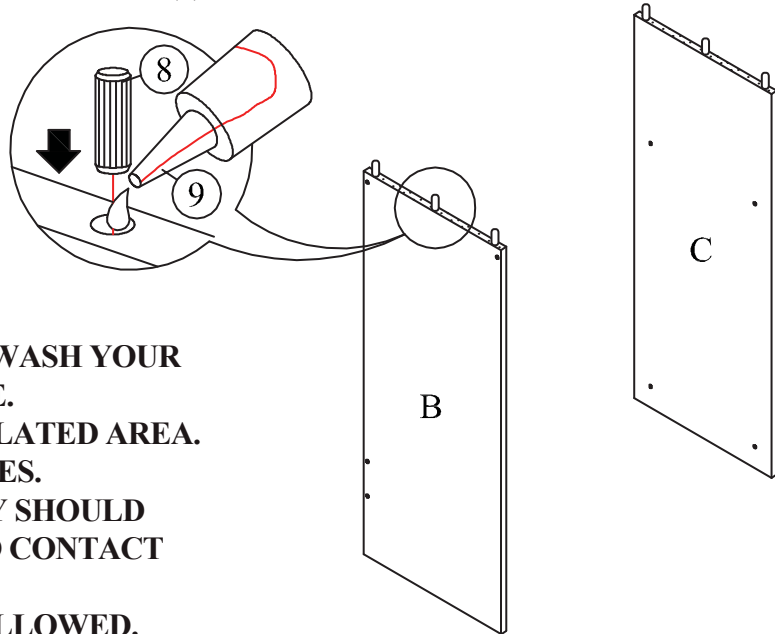

WARNING!

**AVOID CONTAMINATION, WASH YOUR HANDS AFTER USING GLUE.
ONLY USE IN WELL-VENTILATED AREA.
AVOID CONTACT WITH EYES.
RINSE EYES IMMEDIATELY SHOULD THE PRODUCT COME INTO CONTACT WITH THEM.
MAY BE HARMFUL IF SWALLOWED.
USE UNDER ADULT SUPERVISION.**

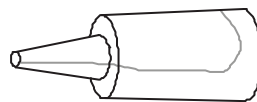

(9) WHITE GLUE - 1 PC

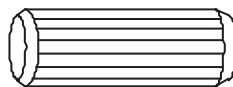

(8) WOODEN DOWEL – 6 PCS

STEP 4

INSERT GLUE (9) INTO THE DOWEL HOLES AND ATTACH SIDE PANELS (B) & (C) TO THE TOP PANEL.

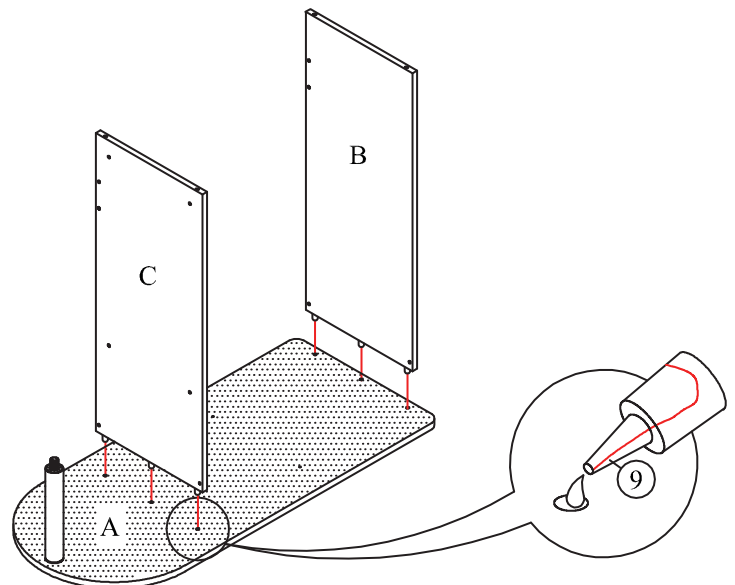

WARNING!

**AVOID CONTAMINATION, WASH YOUR HANDS AFTER USING GLUE.
ONLY USE IN WELL-VENTILATED AREA.
AVOID CONTACT WITH EYES.
RINSE EYES IMMEDIATELY SHOULD THE PRODUCT COME INTO CONTACT WITH THEM.
MAY BE HARMFUL IF SWALLOWED.
USE UNDER ADULT SUPERVISION.**



(9) WHITE GLUE - 1 PC

STEP 5

ATTACH CROSSBARS (D) TO SIDE PANEL (B) & (C) USING SCREW (5).

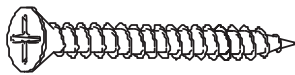
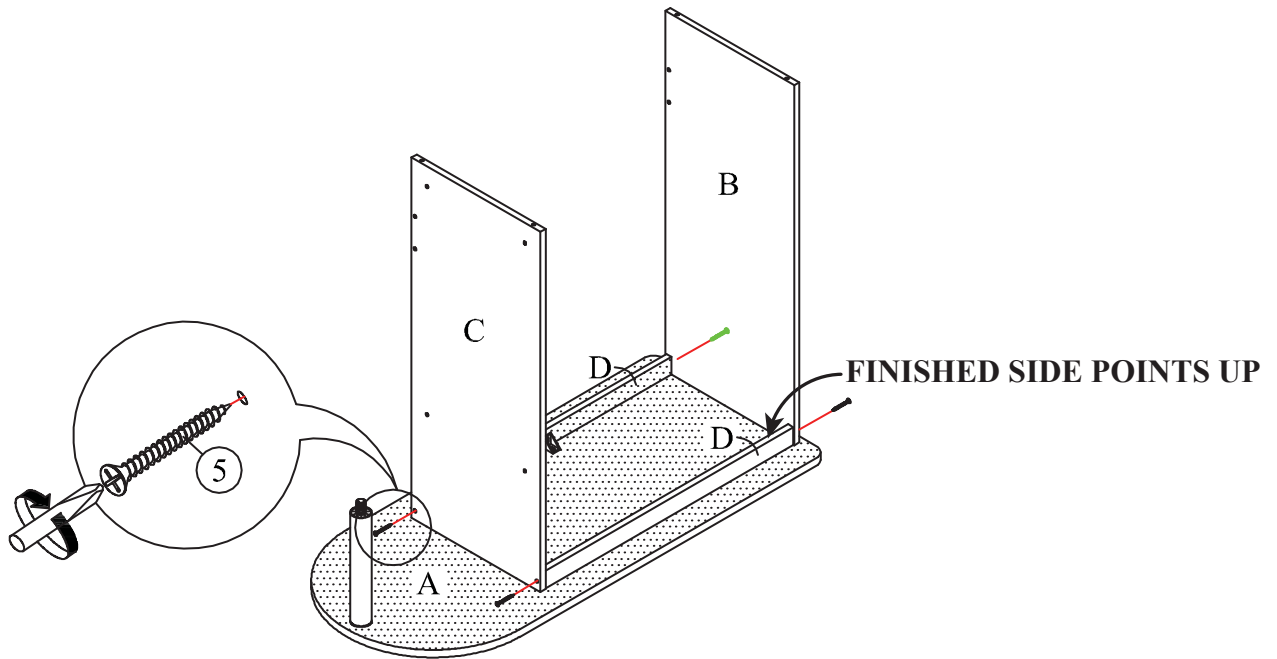

(5) 38MM (1.49") SCREW - 2 PCS

STEP 6

6.1 ATTACH L-BRACKET (7) TO TOP PANEL (A) USING SCREW (6)

6.2 ATTACH BACK PANEL (E) TO SIDE PANEL (B) & (C) USING SCREW (5)

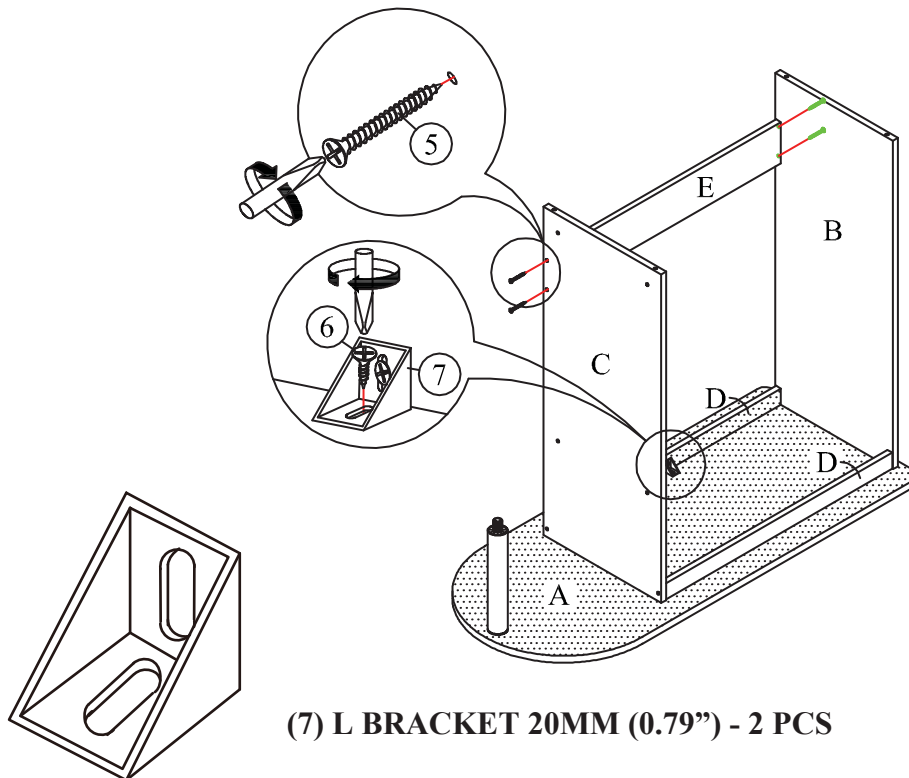

(7) L BRACKET 20MM (0.79") - 2 PCS



(5) 38MM (1.49") SCREW - 2 PCS

STEP 7

ATTACH PLASTIC FOOT W/PIN (10) TO END OF SIDE PANELS (B) & (C) WITH MALLET.

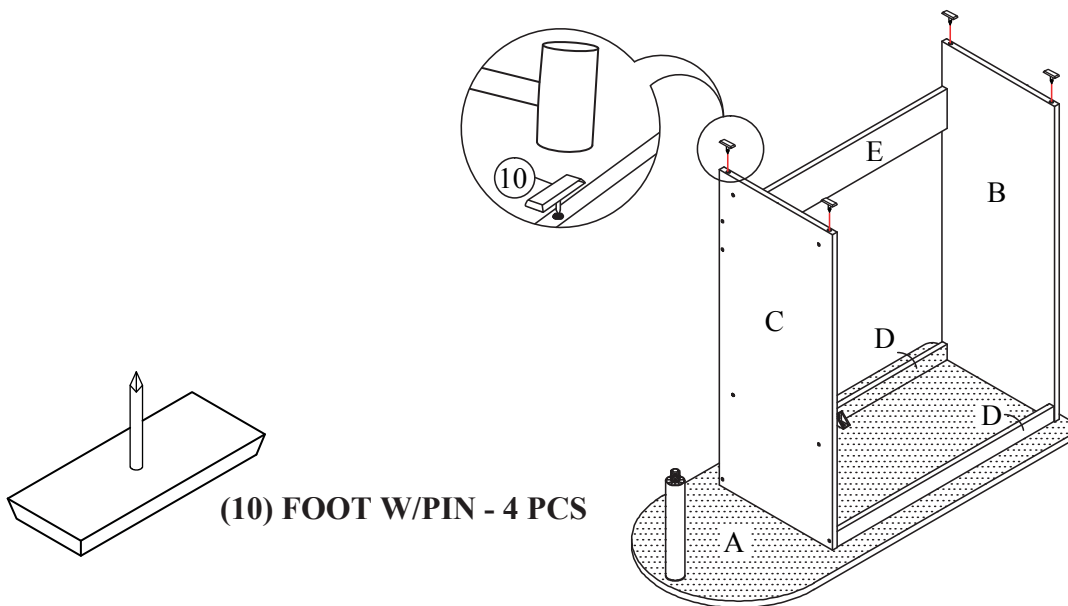

(10) FOOT W/PIN - 4 PCS

STEP 8

ATTACH SIDE CENTER SHELF (F) TO SIDE PANEL (C) USING SCREWS (5). ATTACH LONG TUBE (1) TO MEDIUM TUBE (2). DO NOT OVER TIGHTEN TUBE.

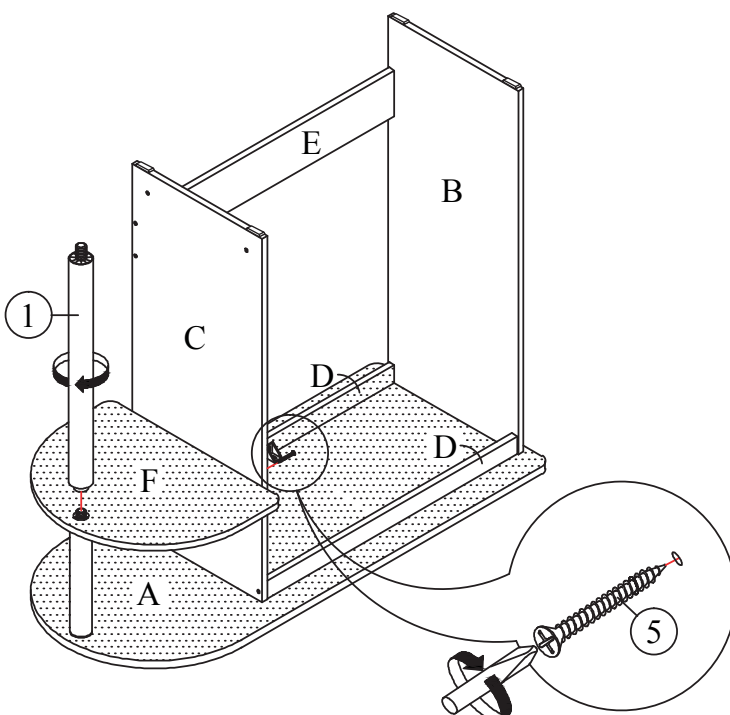

(F) SIDE CENTER SHELF - 1 PC



(1) 44CM (17.32") LONG TUBE - 1PC



(5) 38MM (1.49") SCREW - 2 PCS

STEP 9

**ATTACH SIDE BOTTOM SHELF (G) TO SIDE PANEL (C) USING SCREWS (5).
ATTACH FOOT (3) TO LONG TUBE (1).
DO NOT OVER TIGHTEN FOOT.**

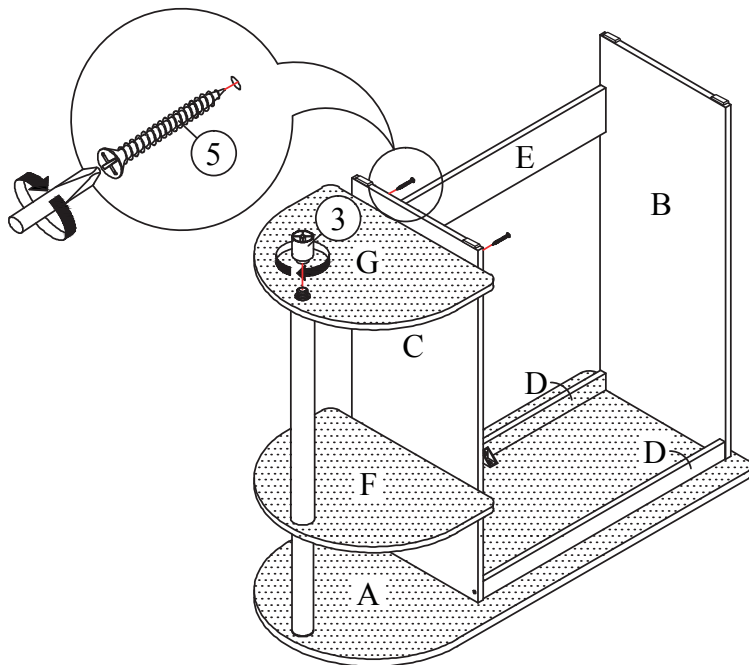

(G) SIDE BOTTOM SHELF - 1 PC



(3) 3.8CM (1.49") FOOT - 1 PC



(5) 38MM (1.49") SCREW - 2 PCS

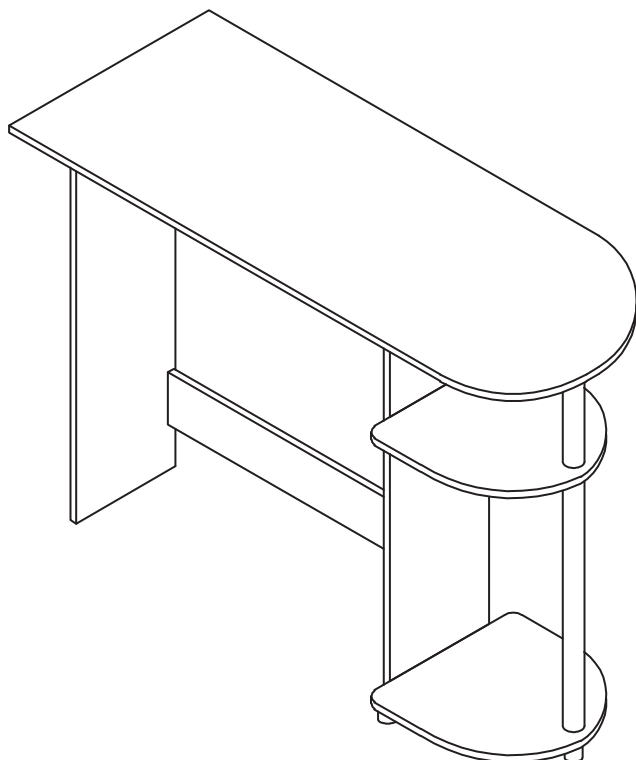

To clean the computer desk, wipe with soft, dry cloth. Apply a small amount of cleaning solution to the cloth if required. Do not use abrasive cleaners in order to prevent the scratching the surfaces.

FINISHED

WARNING!!!

This unit is intended for use only with the products and maximum weights indicated. Use with other products or products heavier than the maximum weights indicated may result in instability causing possible injury. Furniture can tip over or break if improperly moved. Have a friend help to lift and carry the unit to its new location.

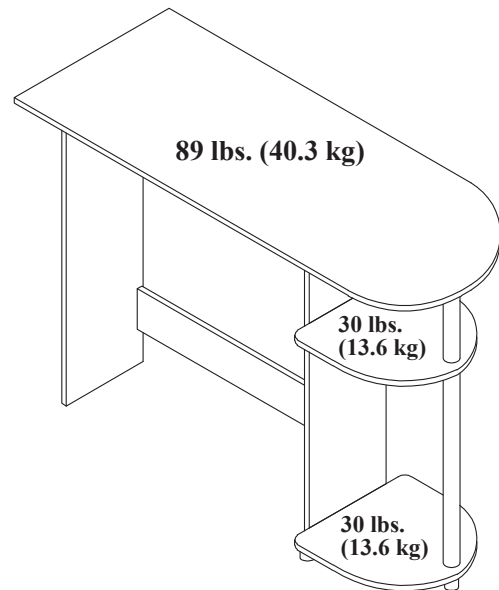

LIMITED 90 DAY WARRANTY

This product is warranted to be free from defects in material and workmanship for a period of 90 days from date of purchase. Warranty is valid for the original purchaser only; proof of purchase from an authorized retailer required. Warranty is limited to replacement of missing and/or defective part(s). If a part is proven defective within the term of this warranty, manufacturer will furnish a replacement part at no cost. No assembly or labor included. This warranty is your sole remedy of product defect and does not cover damage due to mishandling, neglect, moisture, misuse, abuse or non-residential use. The manufacturer is not responsible for incidental or consequential damages. This warranty gives you specific legal rights and you may also have other rights which may vary from state to state.



Do not return to the store

**Do you have any questions ? Missing small parts or hardware?
If you need assistance with the assembly of your COMPUTER DESK
please contact our Customer Service Department by visiting
www.fourstari.com or emailing us at support@fourstari.com or call us at
508-473-7688 or 800-639-3803 or write us at Fourstar Group Customer
Service, 26840 Fargo Ave. , Suite C, Bedford Heights, OH 44146.**

STOP!

**Missing Small Parts Or Hardware
Or Need Assistance?**

No Need To Go Back To The Store!

The store where you made your purchase does not stock hardware for this item. If you need hardware or small parts, contact Customer Service. We will happily ship your part, free of charge, within 48 hours of your request.

Please provide the following information:

- Name of the store purchased from.
 - Date of purchase.
- Item, model, style or SKU number listed on the instructions or box.
- Description of the actual item in question.
 - Part number, description of the part and quantity needed.
 - Copy of proof of purchase from an authorized retailer is required

**This information will help use
fulfill your request efficiently.**

**Contact Customer Service:
Email us at support@fourstari.com or visit
www.fourstari.com**

Or Call Us At (508) 473-7688 or (800) 639-3803

**Hours of Operation are:
Monday – Friday 9am to 4pm Eastern Time**